

High-response proportional flow control valve ESH-G03,04,06

80 to 600 ℓ /min
28,32MPa

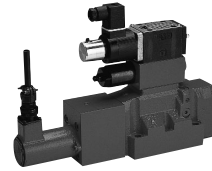

Features

- Main spool minor feedback for greatly increased hysteresis and repeatability.
- Response characteristics suitable to 20Hz and high precision acceleration control.
- Recovery of center position following amp power off or wiring disconnection (Failsafe Function).
- Single rod cylinder spool available for easy use.
- Built-in pilot pressure reducing valve for stable operation.

Specifications

Item	Model No.		ESH-G03-D*****-(*)-11	ESH-G04-D*****-(*)-11	ESH-G06-D*****-(*)-11
	P,A,B Ports	External Pilot Internal Pilo	28{286}	32{327}	32{327}
Maximum Operating Pressure MPa{kgf/cm ² }	Internal Pilo		25{255}	25{255}	25{255}
	T Port		21{214}	21{214}	21{214}
	Pp Port		25{255}	25{255}	25{255}
Minimum Pilot Pressure MPa{kgf/cm ² }			1.5{15}	1.5{15}	2.0{20}
Rated Flow Rate ℓ /min (Rated stroke, P→A pressure drop of 1MPa {10kgf/cm ² } flow rate)			80	180	350
Maximum Flow Rate ℓ /min			140	300	600
Pilot Pressure Reducing Valve Set Pressure MPa{kgf/cm ² }			2.0{20}	2.0{20}	4.0{40}
Hysteresis %			0.5 max.	0.5 max.	0.5 max.
Step Response ms (0→100% displacement)			50{Note1}	50{Note1}	50{Note1}
Frequency Response Hz (±10% input, 90° phase delay)			20{Note1}	20{Note1}	20{Note1}
Pilot Flow Rate ℓ /min			4	8	12
Y (DR1), L (DR2) allowable back pressure MPa{kgf/cm ² }			0.2{2}	0.2{2}	0.2{2}
Weight kg			8	12	18

Note 1. Step response is typical value for a supply pressure of 7MPa {71kgf/cm²} and fluid temperature of 40°C (kinematic viscosity: 40mm²/s).

Understanding Model Numbers

ESH - G 04 - D 5 180 S1 - (*) - 11

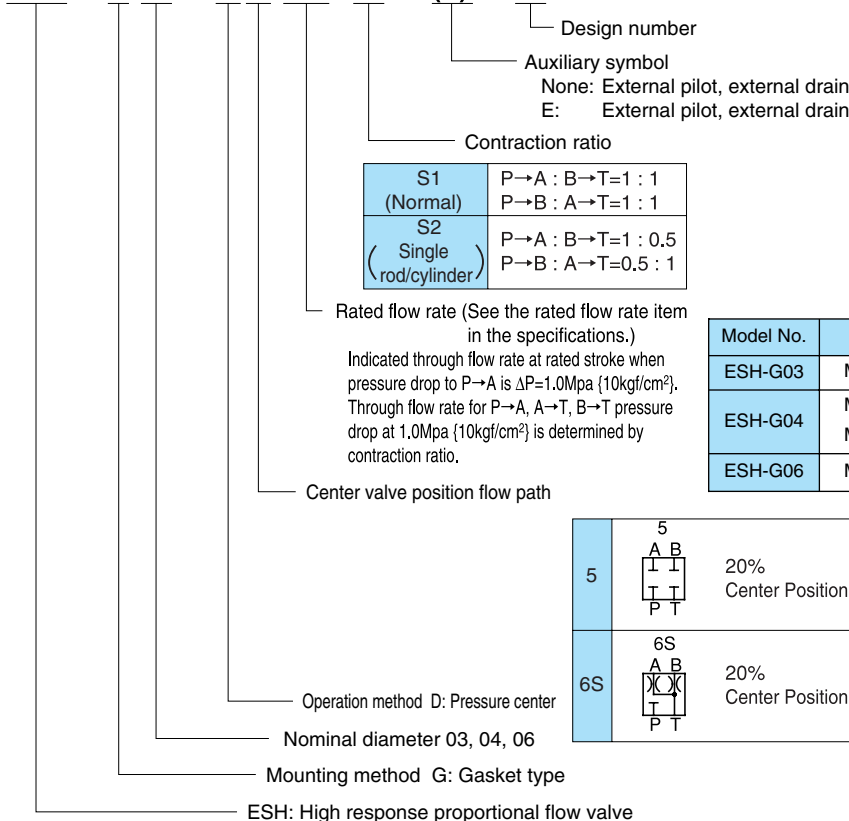

• Handling

1 Air Bleeding

In order to ensure stable control, loosen the air vent and bleed air from the valve before starting operation.

2 Y (DR1), L (DR2) Ports

Connect ports Y (DR1) and L (DR2) directly to the fluid tank so they are always supplied with operating fluid, in order to keep back pressure no greater than 0.2MPa {2kgf/cm²}.

3 L (DR2) Port

Since this valve is a pressure center type, G04 and G06 have an L (DR2) port. Be sure to connect this port directly to the fluid tank.

G03 has a Y (DR1) port only, and this is connected internally to L.

4 Valve Mounting Orientation

Install the valve so the spool axis line is horizontal.

5 Filtration

Maintain hydraulic operating fluid contamination so it is at least NAS Class 9.

6 The amp and valve are adjusted to match at the factory, so be sure to use items that have the same MFG No.

7 Mineral oil hydraulic operating fluid is standard. Use an R&O type and wear-resistant type of ISO VG32, 46, or 68 or equivalent.

8 Use an operating fluid that conforms to the both of the following.

Kinematic viscosity: 20 to 140mm²/s
Oil temperature: 30 to 60°C

9 Electrical wiring between the amp and valve should be no longer than 30 meters. For the solenoid valve use VCTF 2 mm² 2-conductor shielded wire, and for the differential transformer use VCTF 0.5 mm² 4-conductor shielded wire.

10 Bundled Accessories (Valve Mounting Bolts)

Model No.	Bolt Size	Q'ty	Tightening Torque N · m {kgf · cm}
ESH-G03	M 6 × 35 ℓ	4	10 to 13 {102 to 133}
ESH-G04	M10 × 50 ℓ	4	45 to 55 {460 to 561}
	M 6 × 45 ℓ	2	10 to 13 {102 to 133}
ESH-G06	M12 × 60 ℓ	6	60 to 70 {610 to 715}

11 With G03 and G04, providing command in the range of 0 to +10V to the amp's RF input produces a flow of P→A→B→T. With G06, flow is P→B→A→T.

12 For G03 and G04, connect the ports and actuator to achieve a working of P→A→B→T. For G06, connect for a working of P→B→A→T.

13 Contact your agent for a contraction ratio S2 with the G06 size.

Installation Dimension Drawings

JIS Symbol

ESH-G03

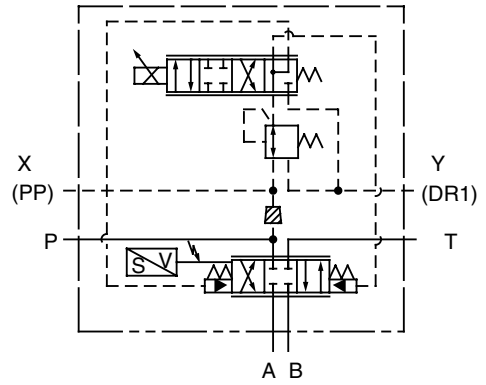
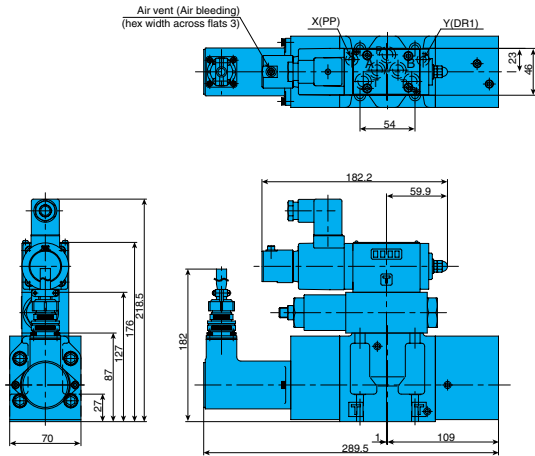

ESH-G04

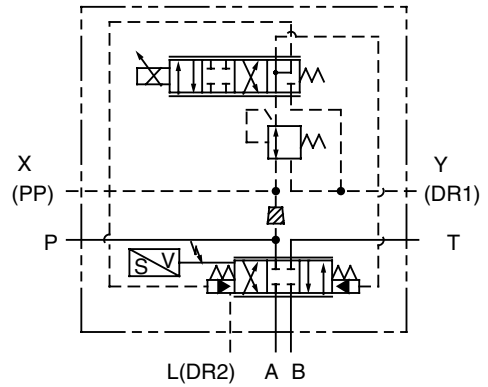
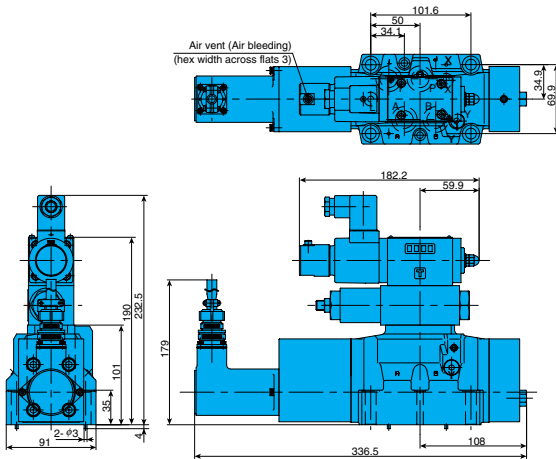

ESH-G06

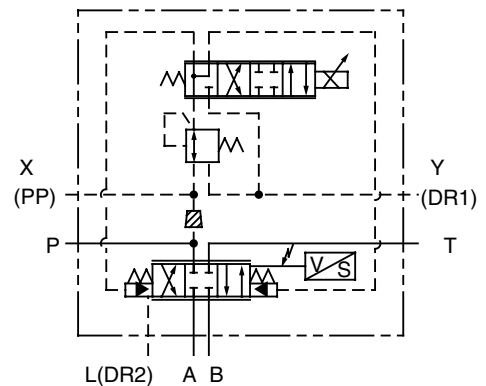
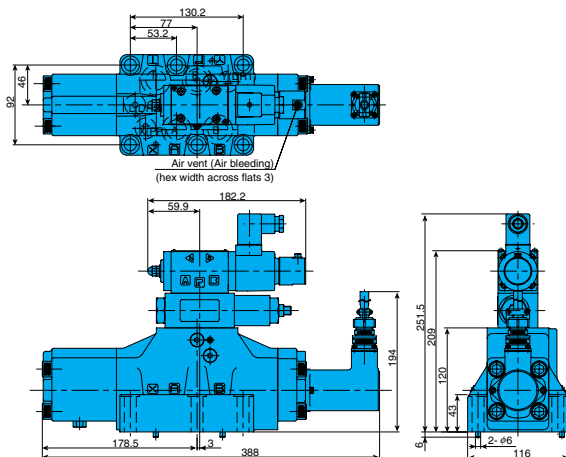

Note:
A stopper plug is needed for the  area if the pilot is external.

Gasket Surface Dimensions

For G03, see ESD-G03 gasket surface dimensions, and for G04 and G06, see Dss-G04, 06-**-20 gasket surface dimensions. Y (DR1) and L (DR2) are required.

Gasket surface dimensions conform to the following.

G0 : ISO 4401-03-02-0-94

G04 : ISO 4401-07-06-0-94

G06 : ISO 4401-08-07-0-94